



The Signalpoint range of flammable, toxic and oxygen gas detectors offer users a low cost solution to their indoor gas monitoring needs

Signalpoint



One-Stop Shop

- Flammable, toxic and oxygen versions available
- IP54 as standard
- Suitable for indoor use

Proven Sensor Technology

- Surecell™ electrochemical sensors
- Poison resistant catalytic bead
- Fast and reliable

Combustible Version

- ATEX hazardous area approval
- Performance to EN50054
- Typical 5 year operational life

Toxic and Oxygen Versions

- Indoor non hazardous area use
 - Local LED indication of status (operation, A1 and A2)
 - Performance to EN45544*
 - Typical 2 year operational life
- * H2S version only

Easy to Use

- Factory set operation
- Simple to replace sensors
- Minimal training required

Friendly Installation

- Wall or ceiling mounting
- Integral junction box
- Pre-drilled M20 clearance cable entry

Range of Accessories

- Weather Housing
- Flow adaptor
- Duct mounting kit
- Collecting cone

The Signalpoint range of flammable, toxic and oxygen gas detectors offer users a low cost solution to their indoor gas monitoring needs. Supplied with an integral pre-wired junction box, the detector can be installed using conduit or cable and glands depending on individual site standards.

Two basic arrangements are provided. Flammable detectors offer mV bridge output for use with dedicated gas control systems (such as Unipoint) and are certified under ATEX for use in potentially explosive atmospheres. Toxic and oxygen detectors are designed for use in non explosive atmospheres. They are 2 wire 4-20mA loop powered and can be used with PLC or dedicated gas control systems.

Toxic and oxygen versions of Signalpoint also provide a local LED indication of their status; periodic green flash (OK), flashing amber (warning) and flashing red (alarm). Seconds count and so the front end sensor design ensures fast speed of response even with 'sticky' gases.

Easy installation is provided for. The junction box includes 'hidden' mounting for wall and ceiling fixings. The hinged lid of the junction box ensures both hands are free to complete electrical connections via the M20 clearance cable/conduit entry.

Maintenance requirements are kept simple and to a minimum. Normally used with the Zareba range of industrial controllers, all user adjustments are made at the controller as required. At the end of their operating life, simply replace the sensor before re-configuring the controller. Sensor exchange kits are available to replace the electrochemical sensors used in the toxic and oxygen detectors. The flammable sensor is simply replaced by fitting a new lid complete with sensing element.

Signalpoint offers low cost, easy installation and simple maintenance. As part of any Honeywell Analytics gas detection system you are assured of being surrounded by gas detection equipment you can trust to keep you safe.



Installation Details



Dimensions

Signalpoint flammable and toxic gas detectors have been designed to provide for user friendly installation. The hinged lid, when opened, reveals three mounting holes (suitable for M3.5 or No. 6 wood screws) thereby removing any need for additional mounting brackets. These mounting holes are outside the weatherproof seal to maintain the IP rating.

The hinged lid ensures hands free, unhindered access, to terminals for easy termination of incoming cables. A pre-drilled M20 clearance entry allows connection via conduit or cable with suitable glands. For toxic and oxygen detectors a weatherproof compression gland is recommended. Where the flammable unit is used in potentially explosive atmospheres a suitably certified cable gland must be used.

2 or 3 wire cables with a cross sectional areas of 0.5mm² (20AWG) to 2.5mm² (14AWG) may be used. The use of a screen to ensure maximum protection against false alarms is recommended. Where flammable detectors are being installed in potentially explosive atmospheres ensure necessary local codes of practice are followed.

Whether using Signalpoint flammable, toxic or oxygen gas detectors the use of any dedicated Zareba gas detector controller is recommended to ensure a simple, cost effective solution to your total gas monitoring needs.

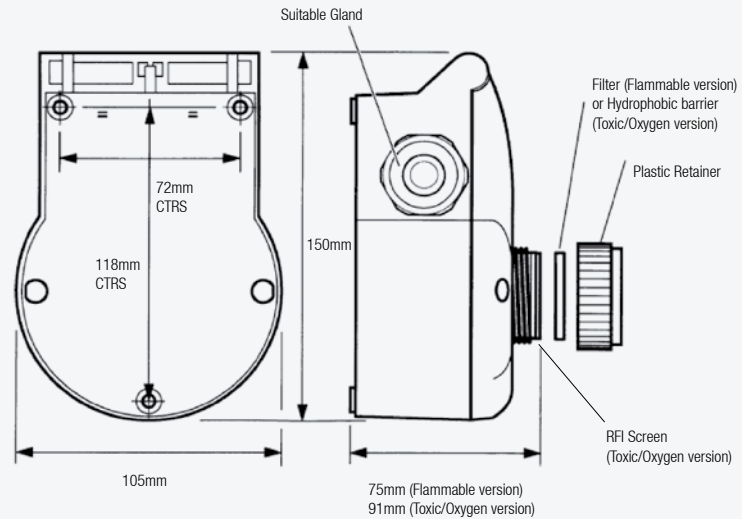

Flammable & Toxic/Oxygen version

Electrical Connections

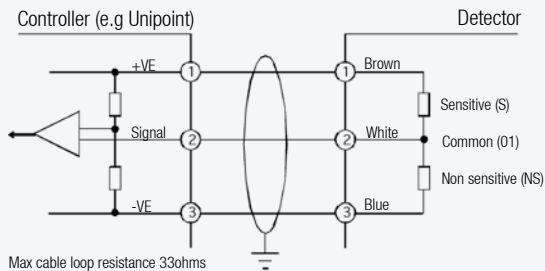
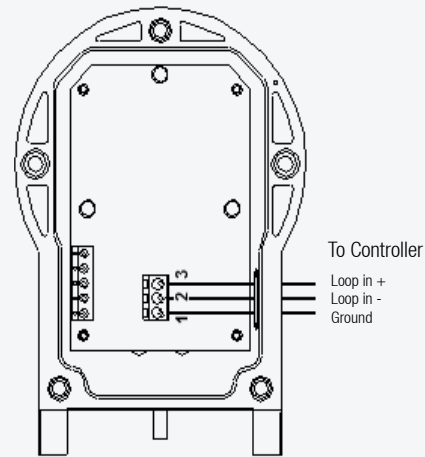
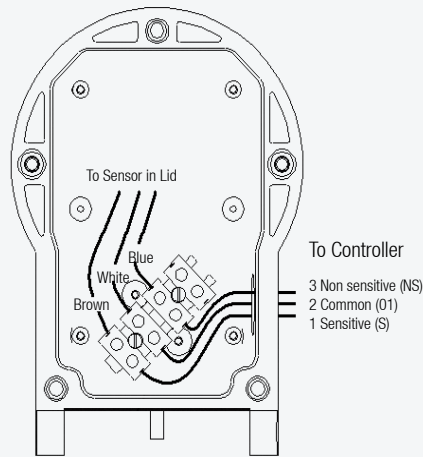

Typical Flammable Detector Connections
(3 Wire mV Bridge Circuit).

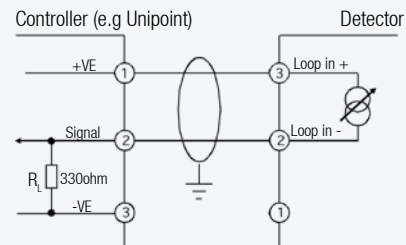

Typical Toxic Detector Connections
(2 Wire 4-20mA loop).

Technical Summary



General Specification				
Use	Low cost, fixed point indoor gas detector for the protection of personnel and plant from flammable, toxic and oxygen gas hazards			
Detectable Gases				
Gas	Range	Warm-up time	Operating Temperature	
			Min	Max
Flammable	100%LEL	< 10 minutes	-30°C / -22°F	+40°C / +104°F
Oxygen	25%VOL	< 5 minutes	-15°C / +5°F	+40°C / +104°F
Carbon Monoxide	100ppm, 200ppm, 500ppm	< 3 minutes	-20°C / -4°F	+40°C / +104°F
Hydrogen Sulphide	20ppm, 50ppm, 100ppm	< 3 minutes	-20°C / -4°F	+40°C / +104°F
Chlorine	5ppm, 15ppm	< 5 minutes	-20°C / -4°F	+40°C / +104°F
Ammonia	50ppm, 1000ppm	< 3 minutes	-20°C / -4°F	+40°C / +104°F
Construction				
Electrical	Flammable (0-100%LEL) 3 wire mV bridge 2.9-3.5V, 200mA constant current, 0.7W (max.) 4 way terminal block. The connecting cabling should be three core multi-strand plus screen with a conductor size of 0.5mm ² (20AWG) to 2.5mm ² (14AWG).		Toxic & Oxygen 2 wire loop powered 4-20mA (plus screen) 16-30V, 0.9W 3 way terminal block. The connecting cabling should be 2 core multi-strand plus screen, with a conductor size of 0.5mm ² (20AWG) to 2.5mm ² (14AWG).	
Material	Sensor: Polyphenylene Sulfide (PPS). Integral Junction Box: Impact resistant Nylon.			
Weight	465g (16.4oz)		495g (17.4oz)	
Certification	Ex II 2G EEx e d IIC T4 Tamb = -30°C to +40°C BAS98ATEX2085X		Safe area use only	
Applicable Standards	This products complies with the relevant CE standards including:			
	EMC to BS EN50081 part 1, BS EN50082 part 1 Performance to EN50054		EMC to BS EN50081 part 1, BS EN50082 part 2 Performance to EN45544	
Environmental				
IP Rating	IP54 in accordance with EN60529:1992			
Operating Humidity Range	Continuous: 20-90%RH (non condensing), Intermittent: 10-99%RH (non condensing)			
Operating Pressure	90-110kPa			
Storage Conditions	0°C to +25°C (32°F to +77°F).			

* Oxygen detection products must only be used to detect oxygen depletion in air.

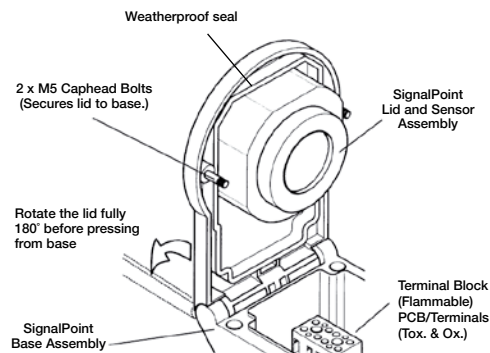

Ordering Information



Ordering Information

Detectors	2106B1100	Signalpoint 100% LEL Flammable Detector
	2106B1300	Signalpoint H ₂ S 20ppm Toxic Detector
	2106B1301	Signalpoint H ₂ S 50ppm Toxic Detector
	2106B1302	Signalpoint H ₂ S 100ppm Toxic Detector
	2106B1305	Signalpoint CO 100ppm Toxic Detector
	2106B1306	Signalpoint CO 200ppm Toxic Detector
	2106B1307	Signalpoint CO 500ppm Toxic Detector
	2106B1310	Signalpoint Cl ₂ 5ppm Toxic Detector
	2106B1311	Signalpoint Cl ₂ 15ppm Toxic Detector
	2106B1313	Signalpoint NH ₃ 50ppm Toxic Detector
	2106B1314	Signalpoint NH ₃ 1000ppm Toxic Detector
	2106B1316	Signalpoint O ₂ 25% V/V Toxic Detector
	Standard Supply	Each detector is supplied complete with integral junction box, single non threaded M20 entry, hinged lid and instruction leaflet sealed in a plastic bag.
Optional Accessories	02000-A-1645	Calibration gas flow housing (for flammable and toxic)
	02000-A-3120	Calibration gas flow housing (for toxic adsorbent gases)
	02000-A-1635	Weatherproof cap for use with toxic/oxygen detector including remote gassing nozzle
	02000-A-1640	Weatherproof housing for use with flammable detector including remote gassing nozzle
	02000-A-1642	Collecting cone (flammable gases lighter than air)
	02000-A-3120	Flow housing assembly
	2106B1110	Catalytic bridge to 4-20mA converter
	00780-F-0018	Flammable detector sensor filter
	00910-A-0404	Hydrophobic barrier for use with toxic detectors
2106D2097	Gas calibration cap for use with toxic detectors sensor	
Calibration Equipment	Contact Honeywell Analytics Representative	

Our Product Range



Fixed Gas Monitoring

Honeywell Analytics offers a wide range of fixed gas detection solutions for a diverse array of industries and applications including: Commercial properties, industrial applications, semiconductor manufacturers, energy plants and petrochemical sites.

- » Detection of flammable, oxygen and toxic gases (including exotics)
- » Innovative use of 4 core sensing technologies – paper tape, electrochemical cell, catalytic bead and infrared
- » Capability to detect down to Parts Per Billion (ppb) or Percent by Volume (%v/v)
- » Cost effective regulatory compliance solutions

Portable Gas Monitoring

When it comes to personal protection from gas hazards, Honeywell Analytics has a wide range of reliable solutions ideally suited for use in confined or enclosed spaces.

These include:

- » Detection of flammable, oxygen and toxic gases
- » Single gas personal monitors – worn by the individual
- » Multi-gas portable gas monitors – used for confined space entry and regulatory compliance
- » Multi-gas transportable monitors – used for temporary protection of area during site construction and maintenance activities

Technical Services

At Honeywell Analytics, we believe in the value of great service and customer care. Our key commitment is providing complete and total customer satisfaction. Here are just a few of the services we can offer:

- » Full technical support
- » Expert team on hand to answer questions and queries
- » Fully equipped workshops to ensure quick turnaround on repairs
- » Comprehensive service engineer network
- » Training on product use and maintenance
- » Mobile calibration service
- » Customised programmes of preventative/corrective maintenance
- » Extended warranties on products

Find out more

www.honeywellanalytics.com

Contact Honeywell Analytics:

Europe, Middle East, Africa

Life Safety Distribution AG
Wilstrasse 11-U31
CH-8610 Uster
Switzerland
Tel: +41 (0)44 943 4300
Fax: +41 (0)44 943 4398
gasdetection@honeywell.com

Americas

Honeywell Analytics Distribution, Inc.
405 Barclay Blvd.
Lincolnshire, IL 60069
USA
Tel: +1 847 955 8200
Toll free: +1 800 538 0363
Fax: +1 847 955 8208
detectgas@honeywell.com

Asia Pacific

Honeywell Analytics Asia Pacific
#508, Kolon Science Valley (1)
187-10 Guro-Dong, Guro-Gu
Seoul, 152-050,
Korea
Tel: +82 (0)2 2025 0307
Fax: +82 (0)2 2025 0329
analytics.ap@honeywell.com

Technical Services

ha.emea.service@honeywell.com

www.honeywell.com

Please Note:

While every effort has been made to ensure accuracy in this publication, no responsibility can be accepted for errors or omissions. Data may change, as well as legislation, and you are strongly advised to obtain copies of the most recently issued regulations, standards, and guidelines. This publication is not intended to form the basis of a contract.

H_Signalpoint_DS0933_V2_EMEA

09/07

© 2007 Honeywell Analytics

Honeywell